

## Measuring point PNMA II

### Function

The PROFINET measuring adapter II (PNMA II) serves as an access point for feedback-free telegram recording in PROFINET networks and further ethernet-based networks under production conditions. A permanent installation of the measuring adapter in the network connection between the automation device (SPC) and the first switch is recommended, because typically the greater part of the communication converges in this connection. Therefore two network sockets (network P1 and P2) are available at the unit.

To connect an analysis tool non-reactively (PN-INSpektor® or laptop) two monitor sockets are provided (monitor M1 and M2). Thus it is possible to monitor in parallel both communication directions. An analysis tool is connected to the monitor sockets by two network lines. To analyse and evaluate the measuring results, the telegrams from both communication directions can be superimposed in terms of time. Error telegrams are not rejected by the PNMA II but forwarded.

### Comparison: Telegram record during online mode

#### Recording by port mirroring at the switch

- Advantages:
- No additional hardware required (no PNMA II)
- Disadvantages:
- Time-consuming set-up of the mirror port at the switch
  - High load of the switch by the mirror port
  - Package losses at high data rates
  - Bidirectional mirror port urgently required
  - Defective telegrams are not mirrored

#### Recording by PNMA II

- Advantages:
- No vacant switch port required
  - No efforts on connecting a measuring tool
  - Unconditionally bidirectional up to 100 Mbps
- Disadvantages:
- Additional hardware

### Technical data

- Installation: 35 mm DIN top-hat rail
- Dimensions (H x W x D): 105 x 38,9 x 75 mm
- Weight: 420 g
- Voltage input: 24 VDC (20-28 V, reverse polarity protected)
- Output voltage: 24 VDC (max. 1A)
- Max. power consumption: 50mA
- Max. power loss: 1W
- Protective system: IP20
- Connector: RJ45
- Delay time: Less than 1 Bps at 100 Mbps
- Cable: Cat 5 / Cat 5E, max. 100 m
- Operating temperature: 0 °C to +50 °C
- Storage temperature: -15 °C to +75 °C
- Air humidity: 10 to 90 %, non-condensing

### Information to connecting

To connect the PROFINET-INSpektor® via PNMA II two patch cables are required (crossover cable is not needed).

In case of a power supply failure of the PNMA II the PROFINET communication via the PNMA II remains constant.

For power supply of additional analysing tools the port UOUT (24VDC) is provided for.

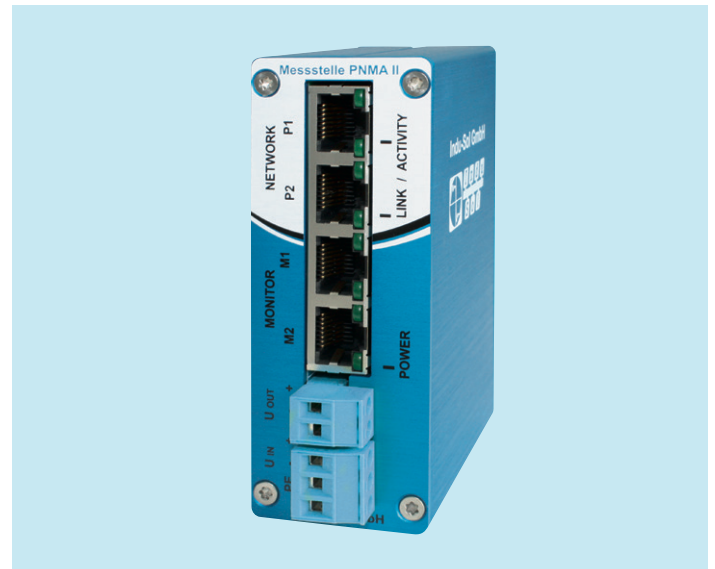

Measuring point PNMA II

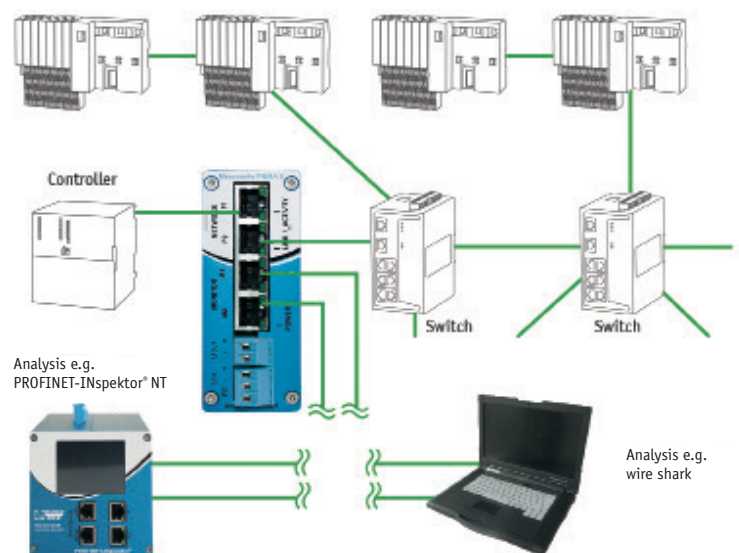

Example of topology - temporary telegram analysis

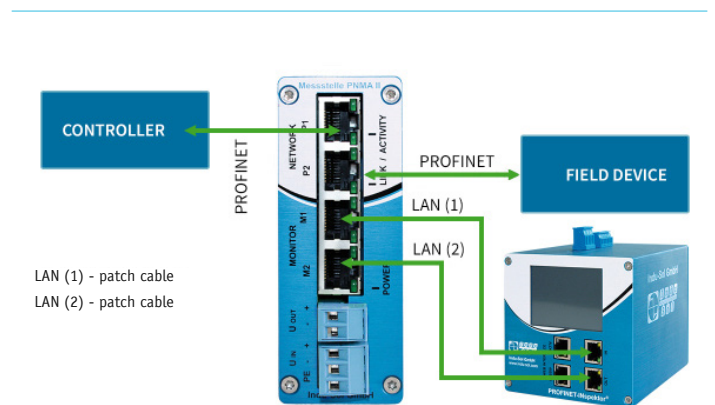

Example of connection

Ordering details	Art. No.
Measuring point PNMA II	114090100